



ADDENDUM NUMBER: 1
PROJECT NAME: DeSaussure E&G Window Replacement Project
PROJECT NUMBER: H27-6117
PREPARED BY: Liollo Architecture
147 Wappoo Creek Drive, Suite 400
Charleston, SC 29412
alison@liollo.com
DATE OF ISSUE: March 28, 2019

TO ALL BIDDERS OF RECORD: This Addendum modifies the Contract Documents only in the manner and to the extent stated herein and shown on any accompanying drawings and will become a part of the Contract Documents. Except as specified or otherwise indicated by this Addendum, all work shall be in accordance with the basic requirements of the Contract Documents.

**BIDDERS SHALL ACKNOWLEDGE RECEIPT OF ADDENDUM WHEN SUBMITTING BID.
THIS ADDENDUM CONSIST OF 2 PAGE(S) AND THE FOLLOWING ENCLOSURES:**

I. ENCLOSURES:

1. Pre-bid sign-in sheet from 3/20/2019.
2. SE-330 Form, page BF3.
3. Drawing Sheet A602.

II. GENERAL INFORMATION / CLARIFICATIONS:

1. A project site visit has been scheduled for Monday, April 1, 2019 at 10:30 am. Interested parties to meet at this time on the horseshoe, in front of the entrance to DeSaussure College, for a guided walk through of the project site.
2. The last day for bidder questions has been rescheduled. All bidder questions must be submitted by noon on Tuesday, April 2, 2019.
3. The closing date has been rescheduled and will be held at 1300 Pickens Street, Conference Room 100C on Monday, April 8, 2019 at 2:00 pm.

III. CHANGES TO SPECIFICATIONS - Replace the specification page previously issued with the sheets of the same name attached to this addendum.

1. SE-330 Form, page BF 3, Item 9.a, Contract Time, has been revised to 90 calendar days.

IV. CHANGES TO DRAWINGS - Replace the drawing sheets previously issued with the sheets of the same name attached to this addendum.

1. A602: Detail 1 "Typical Window Details" updated to indicate that all upper window sashes are to be fixed, and all bottom sashes are to be fully operable.

V. QUESTIONS / ANSWERS:

None

VI. SUBSTITUTION REQUESTS:

None.

END OF ADDENDUM

**University of South Carolina
Non Mandatory Pre Bid Sign In Sheet
Columbia, SC**

Project Name: DeSaussure E&G Window Replacement
 Project Number: H27-6117
 Pre Bid Date & Time: March 20, 2019 1300 Pickens St Conf Rm 100C

SWMBE Contractor Indicate Below	Name	Company Name	Address	Phone #	Email
S W M B E	Florence Ogburn	FNO Construction & Assoc	P.O. Box 28456 Columbia, SC	(803) 363-7760	fogburn@gmail.com
S W M B E	Tommy Schimpf	LIOLLO ARCHITECTURE	117 Wappoo Court Columbia, SC 29912	843-762-2222	tommy@liollo.com
S W M B E	JAMES SHERRY	USC	1520 DEVINE STREET COLUMBIA SC 29208	803 777-5719	JSHERRY@MAILBOX.SC.EDU
S W M B E	Jo Wessinger	USC Honors College	Horseshoe	777-2128	jo@schc.sc.edu
S W M B E	TRAVIS MELTON	MW MILLWORKS	7225 PEPPERWICK PKWY N. CHARLESTON SC 29418	843 746-8540	TRAVIS@MWMILLWORKS.COM
S W M B E	DAVE ELLIS	HUSS INC	1005 SAINT ANDREWS BLVD	843-937-0023	David@hussinc.com
S W M B E	Aimee Rish	USC FAC proc	1300 pickens st Columbia SC 29208	803-777-2261	arish@mc.sc.edu
S W M B E					
S W M B E					

***By signing this sheet you agree to receive information electronically.

SE-330 LUMP SUM BID FORM

§ 8. LIST OF MANUFACTURERS, MATERIAL SUPPLIERS, AND SUBCONTRACTORS OTHER THAN SUBCONTRACTORS LISTED IN SECTION 7 ABOVE (*FOR INFORMATION ONLY*):

Pursuant to instructions in the Invitation for Construction Services, if any, Bidder will provide to Owner upon the Owner's request and within 24 hours of such request, a listing of manufacturers, material suppliers, and subcontractors, other than those listed in Section 7 above, that Bidder intends to use on the project. Bidder acknowledges and agrees that this list is provided for purposes of determining responsibility and not pursuant to the subcontractor listing requirements of SC Code § 11-35-3020(b)(i).

§ 9. TIME OF CONTRACT PERFORMANCE AND LIQUIDATED DAMAGES

a) CONTRACT TIME

Bidder agrees that the Date of Commencement of the Work shall be established in a Notice to Proceed to be issued by the Owner. Bidder agrees to substantially complete the Work within 90 Calendar Days from the Date of Commencement, subject to adjustments as provided in the Contract Documents.

b) LIQUIDATED DAMAGES

Bidder further agrees that from the compensation to be paid, the Owner shall retain as Liquidated Damages the amount of \$ 250.00 for each Calendar Day the actual construction time required to achieve Substantial Completion exceeds the specified or adjusted time for Substantial Completion as provided in the Contract Documents. This amount is intended by the parties as the predetermined measure of compensation for actual damages, not as a penalty for nonperformance.

§ 10. AGREEMENTS

- a) Bidder agrees that this bid is subject to the requirements of the laws of the State of South Carolina.
- b) Bidder agrees that at any time prior to the issuance of the Notice to Proceed for this Project, this Project may be canceled for the convenience of, and without cost to, the State.
- c) Bidder agrees that neither the State of South Carolina nor any of its agencies, employees or agents shall be responsible for any bid preparation costs, or any costs or charges of any type, should all bids be rejected or the Project canceled for any reason prior to the issuance of the Notice to Proceed.

§ 11. ELECTRONIC BID BOND

By signing below, the Principal is affirming that the identified electronic bid bond has been executed and that the Principal and Surety are firmly bound unto the State of South Carolina under the terms and conditions of the AIA Document A310, Bid Bond, included in the Bidding Documents.

ELECTRONIC BID BOND NUMBER: _____

SIGNATURE AND TITLE: _____

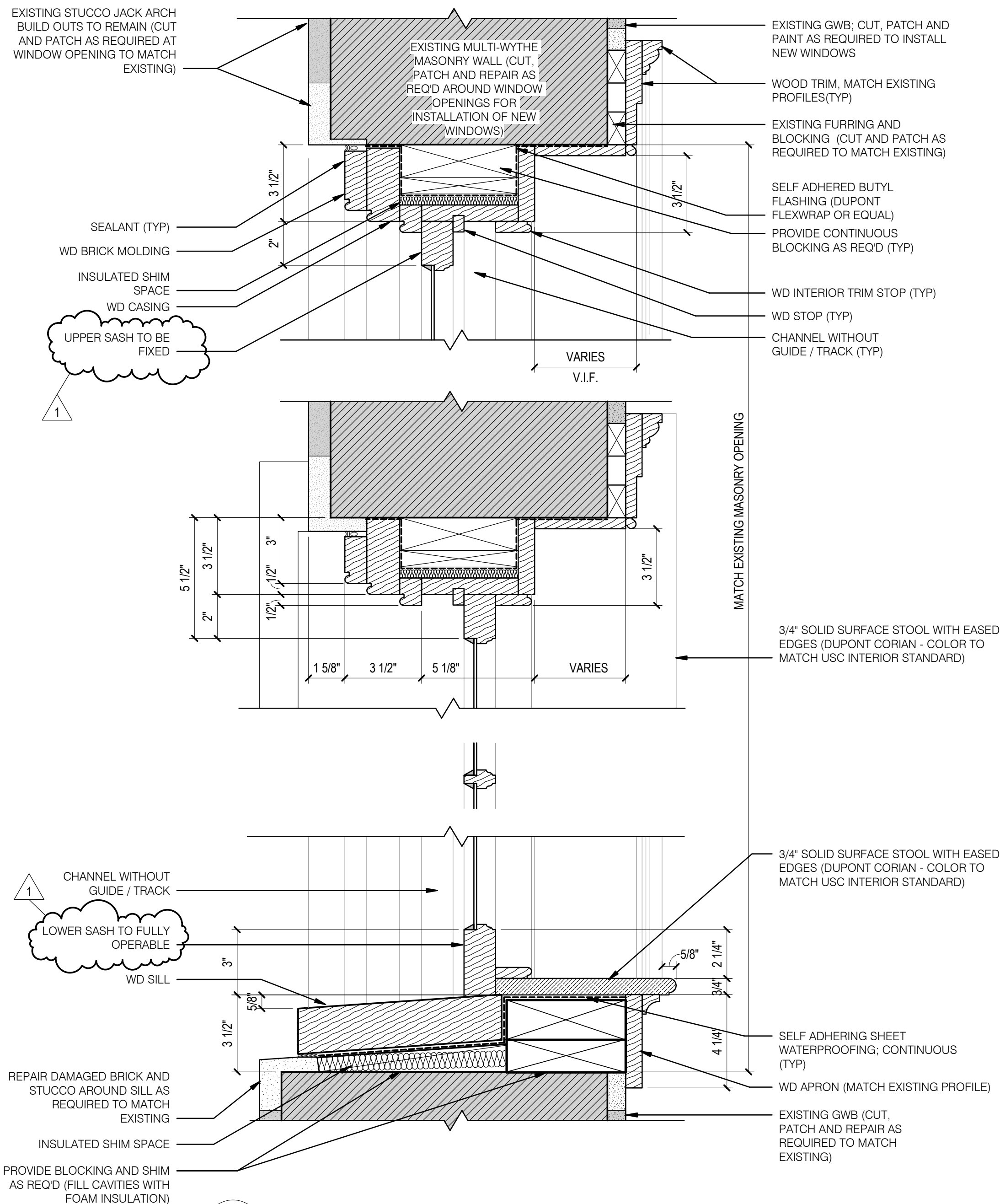

1 TYPICAL WINDOW DETAILS
A602 SCALE: 3" = 1'-0"

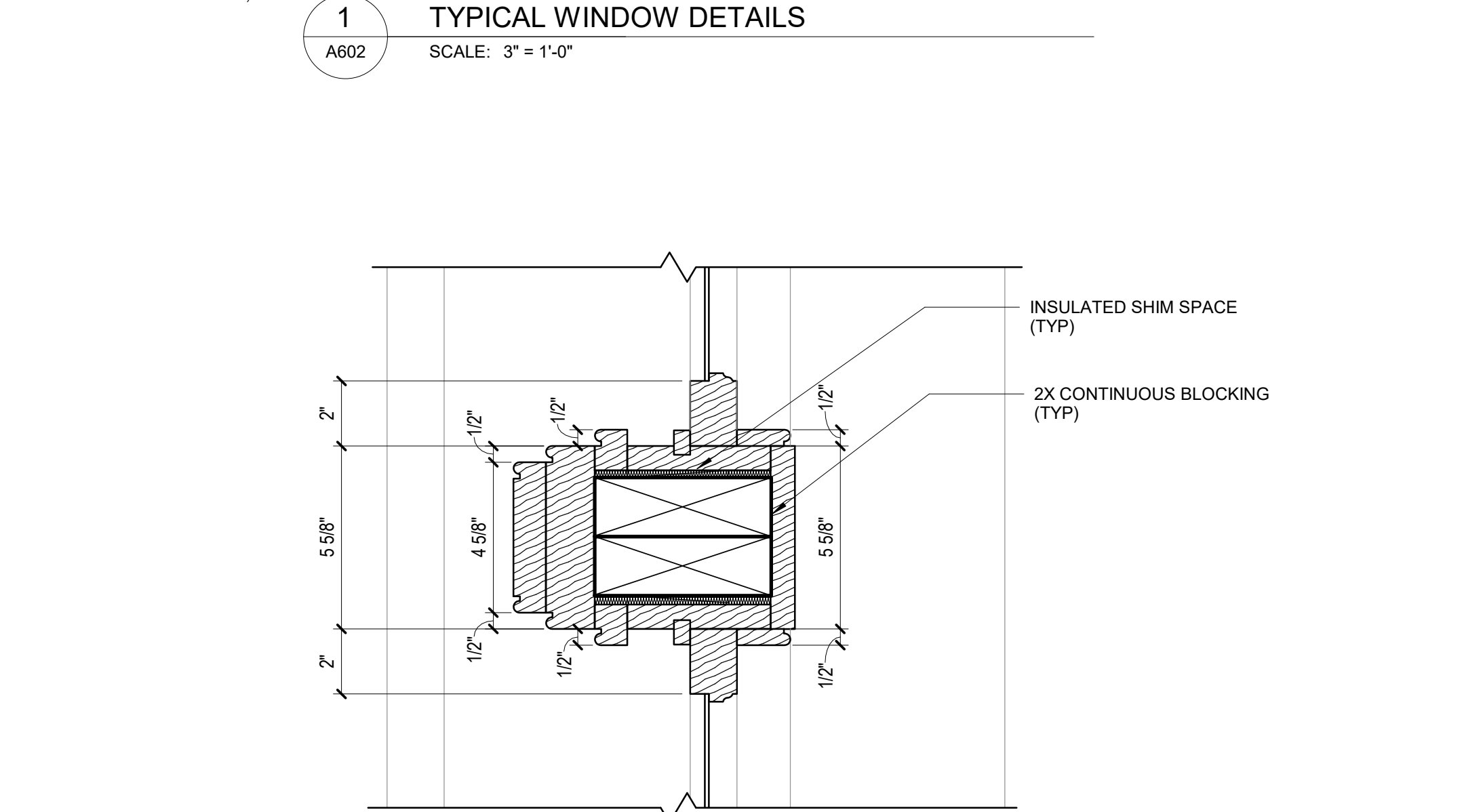

2 TYPICAL WINDOW DETAIL - CENTER JAMB
A602 SCALE: 3" = 1'-0"

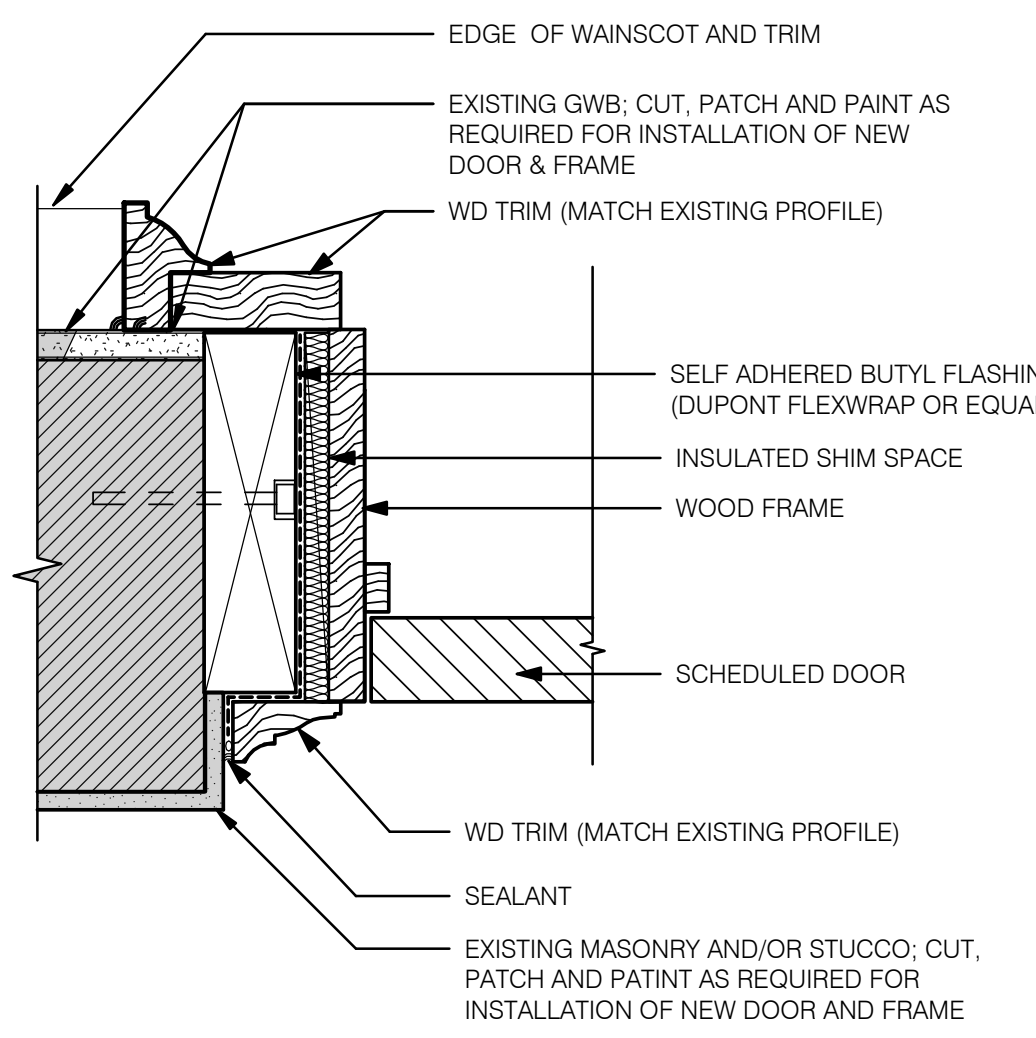

J1

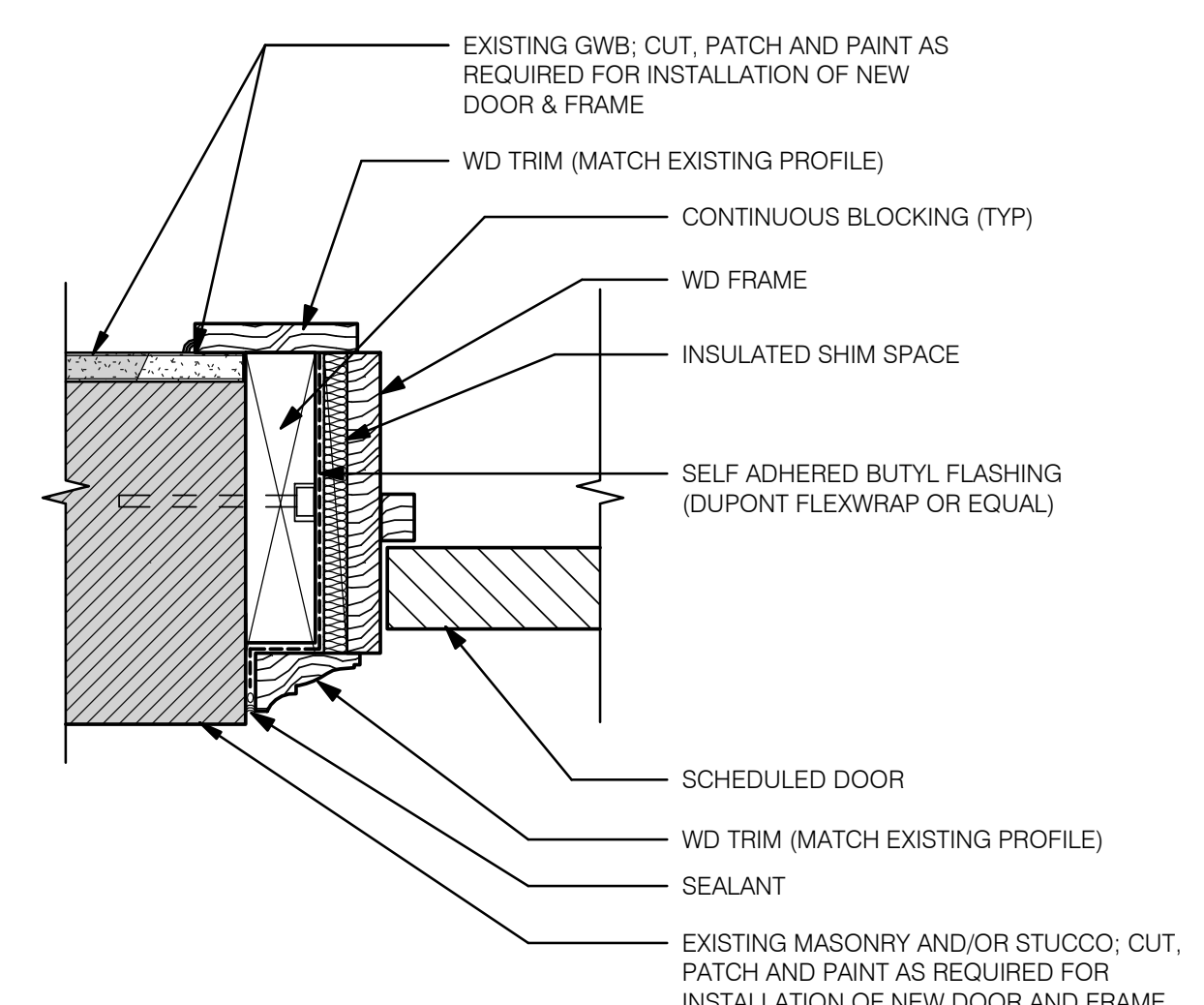

J2

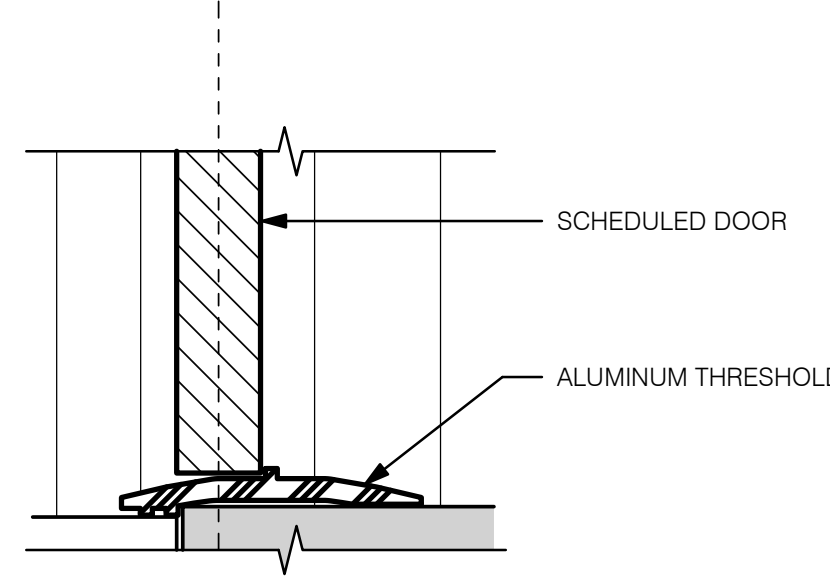

S1

3 TYPICAL DOOR DETAILS
A602 SCALE: 3" = 1'-0"

NOTE 1: GC TO VERIFY ALL DIMENSIONS
NOTE 2: ALL BLOCKING TO BE CONTINUOUS AND PRESSURE TREATED. ANY/ALL FASTNERS THAT PENETRATE PRESSURE TREATED WOOD TO BE COMPATIBLE.
NOTE 3: ALL SHIMS TO BE SYNTHETIC



147 Wappoo Creek Drive
Suite 400
Charleston, SC 29412
P 843.762.2222

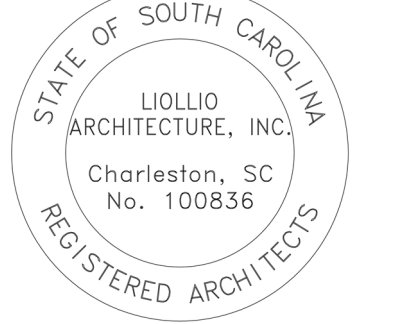
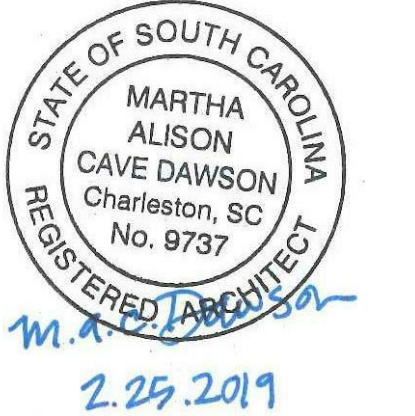

Revision	Date	Description
1	3/26/2019	Addendum #1

University of South Carolina
**DeSaussure E&G
Window
Replacement
Project**

902 Sumter Street
Columbia, SC 29208

State Project Number:	H27-6117
Project Number:	18409
Checked By:	JMW
Drawn By:	ACD
Date:	02/25/2019
Scale:	3" = 1'-0"

**A602
DOOR AND WINDOW
DETAILS**

SCALE: 3" = 1'-0"